

A NOVEL SUBCARRIER ALLOCATION ALGORITHM FOR MC-CDMA SYSTEMS

Muhammet Nuri Seyman — Bircan Saçaklı *

Multi carrier modulation techniques such as MC-CDMA are used in high-speed communication applications. Due to MC-CDMA being a multiuser in technology, the subcarrier quantity allocated per user decreases in case the quantity of active users increases. Consequently, data rates per user are reduced with the increase in the bit error rate (BER). Efficient allocation of subcarriers to users within the system can aid the overcoming of this problem. This study develops a new algorithm for subcarrier allocation and system performance improvement in terms of BER, and data rates in comparison to other algorithms were ensured.

Keywords: MC-CDMA, subcarrier allocation, fairness, data rate

1 INTRODUCTION

The need for higher speeds was brought along with the increased demand in applications requiring wide bandwidth during the latter years. Restriction of the usable bandwidth requires transmission of more than one user from the same transmission environment. Due to this requirement, the multi carrier code division multiplexing technique (MC-CDMA), which provides high rate data transfer, was employed to ensure efficient bandwidth usage [1, 2]. High-speed data transfer with the efficient use of spectrum, and resistance to multipath propagation which is a possibility of multiple users is among the most important advantages of the MC-CDMA system. However, failure to allocate system subcarriers to each user in the required amount leads to increased amounts of data with errors at the receiving point and at the same time decreases data rates. In order to overcome this problem, the subcarrier allocation procedure is executed [3].

Literature has several studies concerning the subcarrier allocation matter [3–17]. Studies [3, 4] performed assignments taking into consideration the channel gains in algorithms used during the allocation processes. Subcarriers providing the user with maximum gain were assigned to that user and such assignment was performed until a conclusion of the allocation procedure was made. Studies [5, 6] first divided users into groups and then performed allocation in accordance with the channel gains.

Number of subcarriers is an important issue in increasing the data rate. [7] presents an algorithm that reduces the system complexity in order for the user to achieve the desired speed. [8] suggests an algorithm that performs allocation in proportion to the user gains. Also [9] performs allocation in proportion to data rates instead of channel gains. The algorithm that first performs assignments to the user who has maximum channel gain variance then as-

signs the remaining carriers to users with minimum data rates which were presented in [10].

When assigning subcarriers, an algorithm should consider user gains, required data rates, system speed and inter-user fairness criteria. Most widely used algorithm in this regard is the Max-Min algorithm [11]. While the XuKim algorithm proposed in [12] follows this algorithm, the Greedy algorithm presented in [12] draws attention. The DaKo algorithm presented in [13] is one of the less frequently used.

The main purpose in the Max-Min algorithm is to increase the system rate by assigning subcarriers to increase data rate of each user beginning from the user with the minimum data rate. Algorithm proposed by Xu and Kim in [12] first assigns the number of subcarriers needed for each user followed by subcarriers in the determined amount that are then assigned to those users. This algorithm increases the system capacity by taking into consideration the fairness criteria. The Greedy algorithm [5] is an algorithm that assigns subcarriers to a user in accordance with the channel gain. The DaKo algorithm [13] was created to maximize system capacity under the limitations of overall usable power, BER and speed rates. However, as can be observed from the literature, certain algorithms do not take fairness into consideration while focusing on the performance in some cases, or certain algorithms focus on the fairness criteria while leaving performance out of sight. However, this study proposes a new subcarrier allocation of algorithm, which takes into consideration both the capacity and fairness criter. Later the algorithm performance was compared to the important algorithms in the literature, the Max-Min, Greedy, XuKim and DaKo algorithms.

* Department of Electronic Communication, Technical High School, 71450, Kirikkale University, Turkey, mnseyman@kku.edu.tr

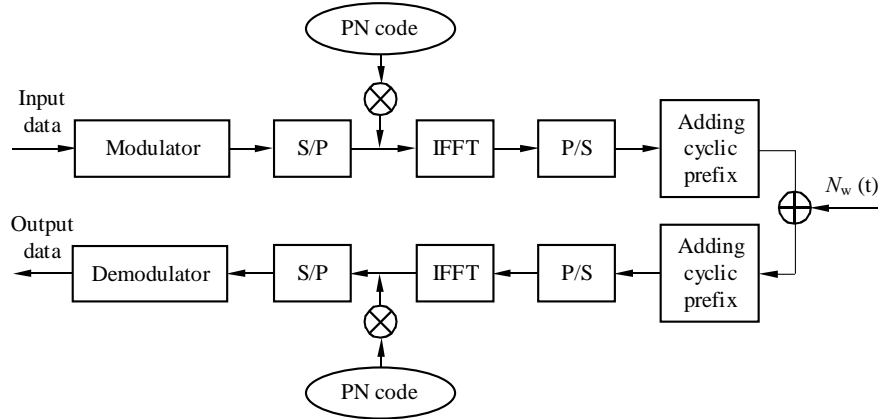

Fig. 1. System model of MC-CDMA

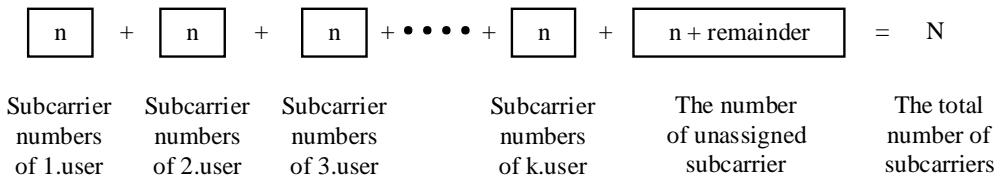

Fig. 2. Total number of subcarrier assignment to the users

2 MC-CDMA SYSTEM MODEL

MC-CDMA is a multi-access method that provides high-speed transmission possibility, efficiently utilizes the transmission line and even shows resistance to probable interferences and multipath losses. The most important property of the MC-CDMA is that it multiplies data using spreading codes called pseudo noise (PN) and ensures its transmission with the same subcarrier structures. In order to prevent interference of signals, these codes need to have orthogonal or minimal cross-correlation with other user codes. Thus, data transfers of more than one user can be carried out at the same time.

As can be seen from the system model of MC-CDMA in Fig. 1, data is multiplied with the PN code, and after the IFFT process, is converted to the time domain. Then, by adding cyclic prefix (CP) data is protected from the inter-symbol interference (ISI). At the receiving side, operations performed in the transmitter section are reversed and data receipt is ensured.

2.1 System Model

When taking into consideration a multiuser MC-CDMA, in a downlink channel with m th user and l th subcarrier, where $m = 1, \dots, M$ and $l = 1, \dots, L$; if we assume that bandwidth is B and overall transmission power is P , the user data rate [14] is

$$R_m = \frac{B}{L} \sum_{(l=1)}^L c_{m,l} \log_2(1 + \gamma_{m,l}). \quad (1)$$

While L is the total number of subcarriers, by considering the bandwidth of each subcarrier is proportional to the total number of subcarriers and is expressed as $\frac{B}{L}$. Here $\frac{B}{L}$ is equal to $\frac{1}{T}$ and $\frac{1}{T}$ is the symbol frequency of MC-CDMA.

$c_{m,l}$ is a parameter that expresses the condition of assigning l subcarriers to a user and acquires the value '1' when the allocation transaction is performed, while acquiring the value '0' otherwise. $\gamma_{m,l}$ is the SNR of m th user's l th subcarrier,

$$\gamma_{m,l} = \frac{P|h_{m,l}|^2}{BL_0}. \quad (2)$$

Here, $h_{m,l}$ defines the channel gain of m th user's l th subcarrier, and L_0 expresses the power spectral density of noise. Proportional data rate criteria for the optimization is formulized as

$$\max_{c_{m,l}} \sum_{m=1}^M \sum_{l=1}^L c_{m,l} \log_2(1 + \gamma_{m,l}), \quad (3)$$

$$C1: c_{m,l} \in \{0, 1\}, \quad \forall m, l, \quad (4)$$

$$C2: \sum_{m=1}^M c_{m,l} = 1, \quad \forall l, \quad (5)$$

$$C3: R1 : R2 \dots : RM = S1 : S2 : \dots : SM. \quad (6)$$

(4), (5) and (6) sequences are the conditions that require attention during subcarrier allocation. Where $S1 \dots SM$ is normalized proportionally constraints.

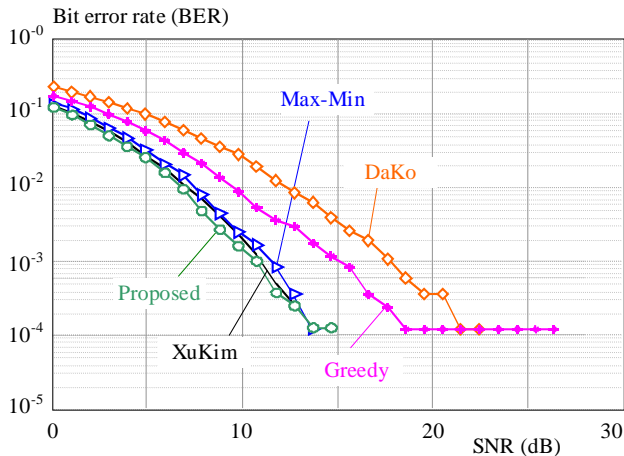

Fig. 3. BER performances for 3 users and 64 subcarrier

Table 1. Simulation parameters

Parameters	Value
Total Power	1 W
Subcarrier Number	64/128/256
Coding Type	Walsh Hadamard
Modulation Type	BPSK
Channel Type	Multipath Rayleigh Fading

2.2 Fairness

Fairness is a parameter described in situations, when subcarriers, strength or bandwidth within a system is equally distributed to users. Depending on the momentary data rate, fairness can be defined as follows.

$$F = \frac{(\sum_{m=1}^M R_m)^2}{K \sum_{m=1}^M R_m^2} \quad (7)$$

defines the data rate of m th users. F takes real value between (0, 1) range. It acquires '1' when subcarriers are allocated to users equally [17].

In non-time-dependent applications, the average data rate is used instead of momentary data rate. In such cases, the fairness equation is expressed as the equality

$$F = \frac{(\sum_{m=1}^M R'_m)^2}{M \sum_{m=1}^M R'_m^2} \quad (8)$$

where R'_m is mean data rate and M is total number of users.

3 PROPOSED ALGORITHM FOR SUBCARRIER ALLOCATION

The distinctive feature of our proposal that differs from other algorithms is the allocation process that not only considers the fairness criteria but also the data rate.

First, the number of subcarrier to be assigned to each user in the algorithm is determined by dividing the total

number of subcarriers with the user count plus one. As a result of the division operation, we have the number of subcarrier to be allocated to each user and non-allocated number of subcarrier. The goal in dividing number of subcarriers with the number of users plus one is to retain the number of non-assigned subcarriers equal to number of subcarrier per user and to assign those subcarriers to users in accordance with their data rates. If there are remaining subcarriers after the division operation, that number is also added to number of non-assigned subcarriers. Determining the number of remaining non-assigned subcarriers in such manner will ensure a fairer distribution in systems with lower numbers of subcarriers in accordance with the user data rates. Total number of subcarrier assignment to the users is illustrated in Fig. 2.

In order to distribute the remaining subcarriers, number subcarriers to be allocated for a user with minimum data rate is increased by one and that user's rate is updated, while the number of non-assigned subcarriers is reduced by one. Some operations are carried out until the number of non-assigned subcarriers reaches zero. Thus, the number of subcarriers to be assigned to each user are determined.

After the number of subcarriers to be assigned to users are determined in such manner, the users are listed in an ascending order from low to high compliance to subcarriers' channel gains. All of the users starting from the first user in the list until the next consequent user corresponding to the half of the total number of users are grouped, and the group is named 'first group' while remaining users are named 'second group'. The assignment begins with the first group.

Subcarriers are assigned to the first user in the group with the minimum channel gain in order to raise that user's data rate then the data rate of user is updated. As can be derived from (1), a user with low channel gain has a low data rate. In order to resume the assigning procedure after the updated data rate, a comparison is carried out among the data rates of users in the first group. Again, the user with the minimum rate is identified and subcarriers required to increase that user's rate are determined and allocated. After updating the user's data rate, the allocation procedure is continued until the number of carriers determined for each of the first group's user is reached. After the allocation procedure is concluded, the same steps are repeated for the second group. Allocations performed in this manner decrease the rate difference among users while contributing to increased speeds of users. Algorithm steps of our proposal are given as follows.

1) Initialization

a) Define the initialized number of subcarriers

$$L_m = \frac{L}{M+1}, m = \{1, 2, \dots, M\}, L_{\text{ass}} = \text{sum}(\text{floor}(L_m))$$

b) $\overline{H}_m = \frac{1}{L} \sum_{l=1}^L (\text{sum } H_{ml})$, \forall_m calculate the average channel gain per user

c) update R_m according to (1)

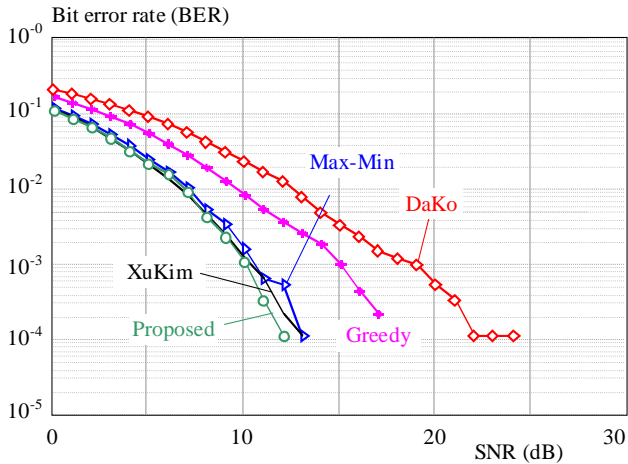

Fig. 4. BER performances for 3 users and 128 subcarrier

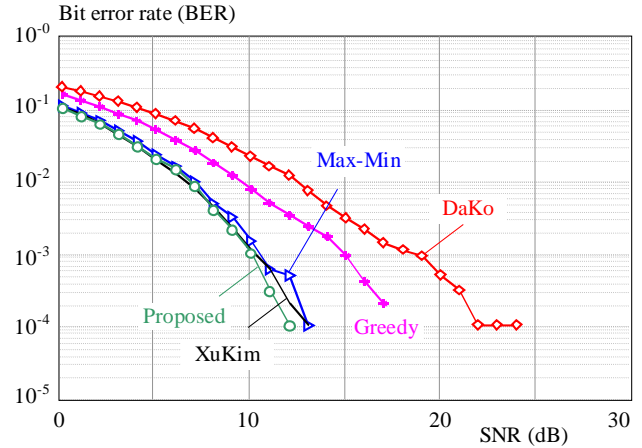

Fig. 5. BER performances for 3 users and 256 subcarrier

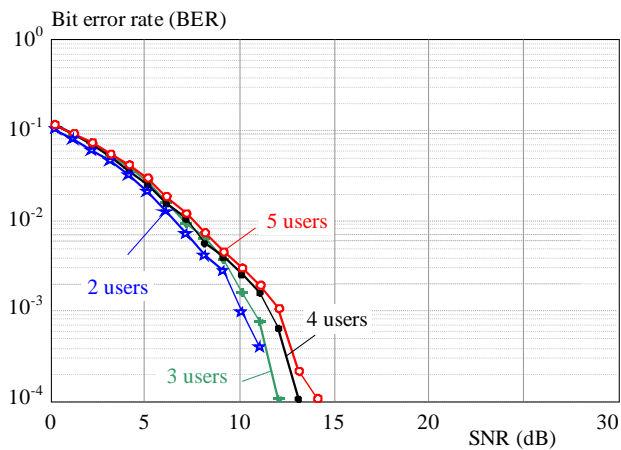

Fig. 6. BER of the proposed algorithm for 128 subcarriers and different number of users

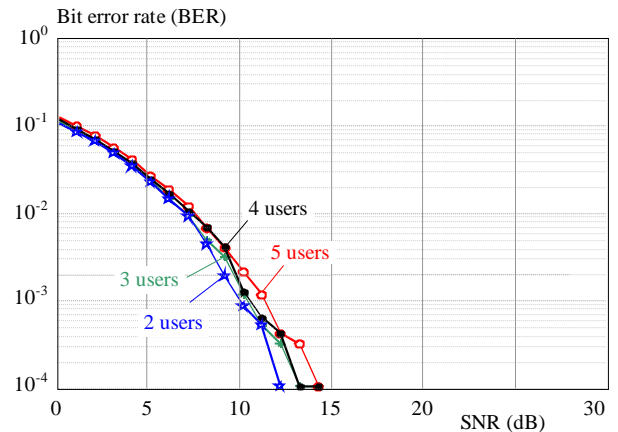

Fig. 7. BER of proposed algorithm for 256 subcarriers and different number of users

- d) While $L_{ass} < L_{mk}$, do
 1. Determine $m' = \operatorname{argmin}_m R_m$, $m = 1, 2, \dots, M$
 $L_{m'} = L_{m'} + 1$, $L_{ass} = L_{ass} + 1$
 2. update R_m according to (1)
- 2) Subcarrier Assignment
 - a) $h_1 \leq h_2 \leq \dots \leq h_s \leq \dots \leq h_M$
 - b) separate the users as two groups
 group(1) = $\{1, 2, \dots, s\}$
 group(2) = $\{s + 1, s + 2, \dots, M\}$
 - c) For $m = 1$ to s
 1. find l by $\max(\prod_{l=1}^L \lambda_{ml})$
 2. $A = A - 1$, $N_m = L_m - 1$, update R_m .
- d) While $|A| > L - \sum_{j=1}^s L_j$
 1. group(1) = $\{1, 2, \dots, s\}$, determine m by $R_m < R_j$ for all j , $1 < j < s$
 2. for the determined m , determine l by
 $l = \max(\prod_{l=1}^L \lambda_{ml})$
 3. if $L_m > 0$
 $A = A - 1$, $L_m = L_m - 1$ and update R_m compliance with (1).
 else
 group(1) = group(1) - m .

4 SIMULATION RESULTS

The simulation parameters of the system are given in Table 1.

Figure 3 shows bit error rate curves for first user of the subcarrier allocation algorithms implemented for 3 users and 64 subcarriers. When we compare algorithms taking into account 10 dB SNR, we can see that while the proposed algorithm gives approximately 1.2×10^{-3} , XuKim gives 1.9×10^{-3} , and Max-Min algorithm gives 2.0×10^{-3} bit error rates, Greedy and DaKo algorithms give 7.5×10^{-3} and 2.5×10^{-2} rates respectively. It is observed that the proposed algorithm shows better performance. Performance of the algorithm implemented in systems with 3 users and 128 subcarriers can be observed from Fig. 4. Our proposal provided better performance in comparison to other algorithms with an approximate 10^{-3} bit error rate in 10 dB SNR. Figure 5 shows first user of BER values corresponding to SNR values of algorithms that allocate 256 subcarriers to 3 users. With the BER value of 10^{-3} , the proposed algorithm provides 1 dB more in SNR gain in comparison to the XuKim algorithm, 2 dB more in comparison to the Max-Min algorithm, 3 dB more in comparison to the Greedy algorithm,

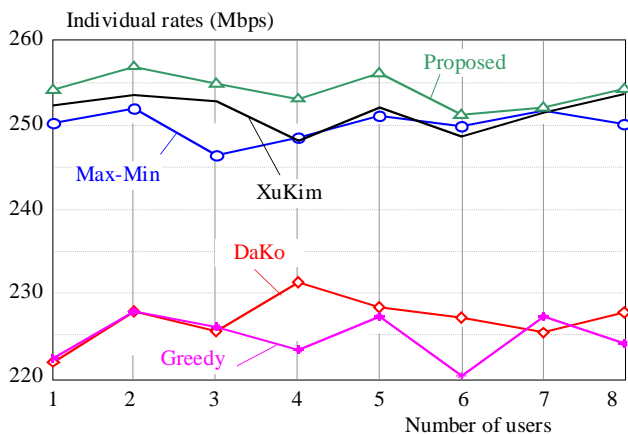

Fig. 8. Individual rate of the algorithms

and 8 dB more in comparison to the DaKo algorithm. Thus, it is obvious that the proposed algorithm provides much better results than other algorithms for 64, 128 and 256 subcarriers.

Figures 6 and 7 show the performance of proposed algorithm with various numbers of users with 128 and 256 subcarriers respectively. Both figures show that BER values increase respectively with the increased user numbers. For instance, Fig. 6 shows that the algorithm in 10 dB SNR gave BER values of 10^{-3} for 2 users, as well as 1.5×10^{-3} , 2.1×10^{-3} , 2.8×10^{-3} for 3 users, 4 users and 5 users in the system respectively. Figure 7 shows that at the same SNR, algorithm performance gave BER values of 8×10^{-4} for 2 users in the system, as well as 10^{-3} , 1.1×10^{-3} , 2×10^{-3} for 3, 4 and 5 users respectively.

Figure 8 shows individual speed increase rates of users in terms of the total user amounts for the algorithm. When using 5 users as a reference point, the Greedy algorithm gave lower results than other algorithms with its value of 2.28×10^8 bps. The Max-Min algorithm with its value of 2.51×10^8 bps and the DaKo algorithm with its value of 2.29×10^8 bps yielded better results. Figure 8 shows that the proposed algorithm with a value of 2.56×10^8 yielded results better than the XuKim algorithm with a value of 2.52×10^8 and other algorithms, thus being the best algorithm for increasing speed.

Algorithm's fairness values, which constitute one of the criteria that needs to be considered during subcarrier allocation, are shown in Fig. 9. When we look at the figure compiled for 7 users; the Max-Min algorithm provides a fairness value of 0.9998, while the Greedy algorithm provides 0.9980, the DaKo algorithm provides 0.9982, the XuKim algorithm gives 0.9991, and the proposed algorithm contributes a value of 0.9992. Fairness receded from its optimum value of 1 as the number of users increased. As the increase in user quantities affects the number of subcarriers per user, the required number of subcarriers cannot be met and the fairness value decreases. Despite the fact that the Max-Min algorithm yields better results

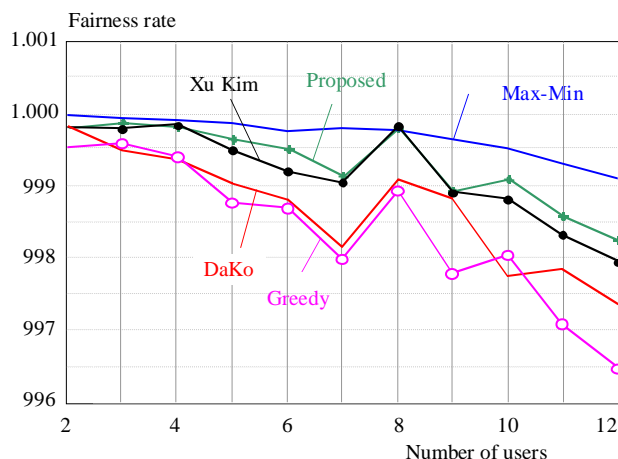

Fig. 9. Fairness comparison

in terms of fairness, it has lower performance degree than our proposal in terms of both BER and individual speed.

5 CONCLUSION

In this paper a new algorithm for assignment of subcarriers in MC-CDMA systems is proposed and the performance of the proposal was compared with other algorithms. As a result of the comparison performed in terms of various quantities of subcarriers and individual speeds, it is concluded that the proposal has a much better performance compared with other algorithms. The most significant feature of our proposal, which separates it from other algorithms, is the fact that it equally considers fairness and data rates during the allocation processes. Thus, results better than those of other algorithms were acquired in terms of both BER and individual speed. Therefore, use of the proposed algorithm can ensure less erroneous and a more optimal data transfer in terms of speed with subcarrier allocation for MC-CDMA systems.

REFERENCES

- [1] PRASAD, R.: CDMA For Wireless Personal Communications Mobile Communication Series, Artech House: Michigan, 1996.
- [2] Van NEE, R., PRASAD, R.: OFDM for Wireless Multimedia Communications, Artech House: London, 2000.
- [3] LIU, G.—YU, F. R.—JI, H.—LEUNG, V. C. M.: Energy-Efficient Resource Allocation in Cellular Networks with Shared Full-Duplex Relaying, IEEE Transactions on Vehicular Technology **64** No. 8 (2015), 3711–3724.
- [4] SHI, J.—YANG, L. L.: Novel Subcarrier-Allocation Schemes for Downlink MC DS-CDMA Systems, IEEE Transactions on Wireless Communications **3** No. 10 (2014), 5716–5728.
- [5] CALDWELL, R.—ANPALAGAN, A.: Adaptive Subcarrier Allocation in Synchronous Reverse Links of a Multicarrier CDMA System with Time and Frequency Spreading, IEEE Transactions on Vehicular Technology **57** No. 3 (2008), 1494–1501.
- [6] Ul HASSAN, N.—ASSAAD, M.: Low Complexity Margin Adaptive Resource Allocation in Downlink MIMO-OFDMA System, IEEE Transactions on Wireless Communications **8** No. 7 (2009), 3365–3371.

- [7] HUANG, P.-H., GAI, Y., KRISHNAMACHARI, B., SRIDHARAN, A.: Sub-Carrier Allocation in OFDM Systems: Complexity, Approximability and Algorithms, In Proceeding of IEEE Wireless Communications and Networking Conference, 2010, pp. 1–6.
- [8] ZHANG, L., ZHANG, S., ZHOU, W.: 1189–1192, In Proceeding of International Conference on Communications, Circuits and Systems, 2006.
- [9] REN, Z.—CHEN, S.—HU, B.—MA, W.: Energy-Efficient Resource Allocation in Downlink OFDM Wireless Systems with Proportional Rate Constraints, IEEE Transactions on Vehicular Technology **63** No. 5 (2014), 2139–2150.
- [10] SADR, S.—ANPALAGAN, A.—RAAHEMIFAR, K.: A Novel Subcarrier Allocation Algorithm for Multiuser OFDM System with Fairness: User'S Perspective, In Proceeding of IEEE Vehicular Technology Conference, 2007, pp. 1772–1776.
- [11] RASOULI, H.—ANPALAGAN, A.: An Asymptotically Fair Subcarrier Allocation Algorithm in OFDM Systems, In Proceeding of IEEE Vehicular Technology Conference, 2009, pp. 1–5.
- [12] XU, J.—KIM, J.—PAIK, W.—SEO, J. S.: Adaptive Resource Allocation Algorithm with Fairness for MIMO-OFDMA System, In Proceeding of IEEE Vehicular Technology Conference, 2006, pp. 1585–1589.
- [13] BIN DA—KO, C. C.—YANFEN LIANG.: An Enhanced Capacity and Fairness Scheme for MIMO-OFDMA Downlink Resource Allocation, In Proceeding of International Symposium on Communications and Information Technologies, 2007, pp. 495–499.
- [14] ZHANG, T.—ZENG, Z.—QIU, Y.: A Subcarrier Allocation Algorithm for Utiliy Proportional Fairness in OFDM Systems, In Proceeding of IEEE Vehicular Technology Conference, 2008, pp. 1901–1905.
- [15] YING, P.—ARMOUR, S. M. D.—McGEEHAN, J. P.: An Investigation of Dynamic Subcarrier Allocation in MIMO-OFDMA Systems, IEEE Transactions on Vehicular Technology **56** No. 5 (2007), 2990–3005.
- [16] RHEE, W., CIOFFI, J. M.: Increase in Capacity of Multiuser OFDM System using Dynamic Subchannel Allocation, In Proceeding of IEEE International Vehicular Tehcnology Conference, 2000, pp. 1085–1089.
- [17] LIU, H-L, WANG, Q.: A Hybrid Evolutionary Algorithm for OFDM Resource Allocation, In Proceeding of IEEE Symposium on Computational Intelligence for Engineering Solutions, 2013, pp. 43–47.

Received 7 December 2015

Muhammet Nuri Seyman works as an assistant professor at Electronic Communications Program of Vocational Technical High School at the Kirikkale University of Turkey. He received the BS, MS and PhD degrees in electronics engineering from Erciyes University, Kayseri, Turkey in 2003, 2005 and 2011 respectively. His current research interests includes multicarrier techniques such as OFDM, MC-CDMA and MIMO systems and applications of artificial intelligence approaches for communications problems.

Bircan Saçakli was born in Ankara, Turkey, on January 14, 1989. She received the BS and MS degrees in electrical – electronics engineering from the Kirikkale University, Kirikkale, Turkey in 2013 and 2015 respectively. She has been working as an electrical electronics engineer at a private company of Turkey since February, 2015.