

Article

Electric Bus Selection with Multicriteria Decision Analysis for Green Transportation

Mustafa Hamurcu * and Tamer Eren * 

Department of Industrial Engineering, Faculty of Engineering, Kırıkkale University, 71450 Kırıkkale, Turkey

* Correspondence: hamurcu.mustafa@kku.edu.tr (M.H.); tamereren@gmail.com (T.E.);

Tel.: +90-318-357-4242 (T.E.)

Received: 27 February 2020; Accepted: 29 March 2020; Published: 1 April 2020



Abstract: Multicriteria decision-making tools are widely used in complex decision-making problems. There are also numerous points of decision-making in transportation. One of these decision-making points regards clean technology vehicle determination. Clean technology vehicles, such as electric buses, have some advantages compared to other technologies like internal combustion engine vehicles. Notably, electric vehicles emit zero tailpipe emissions, thereby ensuring cleaner air for cities and making these clean technologies preferable to other technologies, especially in highly populated areas for better air quality and more livable cities. In this study, we propose a multicriteria decision-making process using analytic hierarchy process (AHP) and Technique for Order Preference by Similarity to Ideal Solution (TOPSIS) in the context of an electric bus in the center of Ankara. Six potential electric bus alternatives were evaluated under seven specific criteria. Overall, EV-2 electric buses outperformed other electric bus alternatives based on the chosen criteria. In addition, the stability of the results obtained under different scenarios using this method was established via sensitivity analysis.

Keywords: electric bus; public transport; analytic hierarchy process; TOPSIS

1. Introduction

Rapid urbanization with increasing population density has caused multiple problems in urban areas. One of the most critical problems is transportation regarding new infrastructure. The emergence of internal combustion vehicles causes traffic problems and affects air quality in city centers [1–4]. Increased car traffic in cities also causes problems such as decreased travel speed for city residents, thereby causing significant time loss both in terms of productivity and leisure. At the same time, traffic congestion threatens accessibility to destination points, especially those that are in the city center. Road safety, increased air pollution, traffic noise, and global warming are also concerns [5]. All of these problems negatively influence the quality of human life and impact the environment.

These social and technical situations require planners and decision-makers to promote change from private cars to public transportation. Public transport is an essential element of urban life since it reduces car traffic and provides city residents with mobility. It also reduces emissions such as carbon dioxide, which has become more critical since the Kyoto protocol was introduced. Greater use of public transport instead of private cars reduces these emissions [6]. Furthermore, public transportation activity is one of the most powerful indicators of economic development and human prosperity in urban areas. Buses play a significant role in the provision of public transportation, being cheap, flexible, and, in many cases, superior in terms of capacity and speed. Therefore, the bus remains the most suitable solution from an economic, environmental, and social point of view in regard to balanced and sustainable urban development. The most crucial problem of transportation concerns sustainability. Briefly, sustainable transportation is defined as “the transportation that meets mobility needs while

also preserving and enhancing human and ecosystem health, economic progress, and social justice now and in the future" [7]. In this respect, environmentally-friendly vehicles should be offered together with developing technology. Rapid deployment of electric buses has received increasing attention around the world in the field of transport, which can be largely accredited to stricter environmental requirements in public transport for emission reductions [8]. In addition to the potential reductions in greenhouse gas emissions via electricity generation from renewable sources, electric buses also offer significant additional benefits, such as reduced energy consumption and noise, compared to engines traditionally used in buses [9,10]. Therefore, electric buses could also help to address air and noise pollution issues [11,12].

Deployment of electric buses has accelerated quickly in the past five to ten years worldwide, with an estimated global battery-electric bus fleet of 345,000 vehicles in 2016. Notably, China possesses nearly 90% of the global electric bus fleet, whereas Europe accounts for 1273 vehicles of the global stock, with only 200 in the USA [13]. Electric bus transportation systems are now consistently part of urban plans made for mass transportation and are used in urban areas. The new technology involves using electricity as an environmentally friendly alternative energy source, thereby making significant improvements in urban areas and increasing city livability. Due to technology developing day-by-day, selecting the most suitable bus technology, including building new buses and developing new characteristics such as environmental friendliness, is of great importance for metropolitan cities.

Urban public transport decision-making is a suitable area for multicriteria decision-making (MCDM) because multiple actors are involved in the design and operation of urban passenger transportation, such as the private and public sectors. However, the decision-making process regarding public transportation is a very complicated task involving multiple economic, environmental, and sociopolitical issues [14]. The selection of a bus system depends on various criteria, such as speed, total passenger capacity, range, power, battery capacity, and charging time. To accommodate this and to evaluate all criteria at the same time, this article utilized an MCDM process to consider the problem of electric bus selection for public transportation using analytic hierarchy process (AHP) and Technique for Order Preference by Similarity to Ideal Solution (TOPSIS) methods for the multicriteria decision-making approach. The hybrid approach included the simplicity of AHP and the efficiency of the TOPSIS method. A decision hierarchy was established, and experts were utilized to assess the pairwise comparison matrices and alternatives.

The following sections of the article are formulated as follows. Section 2 presents an overview of the state of literature about public transport, alternative bus technologies, and decision analyses for the selection process. Section 3 explains the methodology of the AHP, TOPSIS, and integrated AHP–TOPSIS methods. Section 4 presents a case study using the proposed AHP–TOPSIS hybrid decision model for the most suitable selection of electric bus alternatives. In this section, alternatives, the evaluated criteria, research methodology for applications, the selection process, and the results of the selection are given. Finally, the research concludes with some recommendations and suggestions for future studies in Section 5.

2. Literature

Air quality has an effect on human health, with air pollution being at dangerous levels in many parts of the world and millions of premature deaths occurring globally due to poor air quality every year. One of the most essential factors of this situation is vehicle emission [15], with another factor being global warming. The transportation sector has one of the most significant effects on greenhouse gas (GHG) emissions, as conventional vehicles that only use internal combustion engines consume large amounts of fossil fuels. They also emit gases into the natural environment, such as carbon oxides, hydrocarbons, and nitrogen oxides [16], affecting human lives, health, and global warming in the process. These global interactions are further affected by ecosystems and animal habitats, and also the use of natural supplies [17,18].

Production decline in global oil reserves and stringent environmental policies are needed to create new and clean transportation technologies [19–22]. Full electric vehicles and hybrid electric vehicles, which involve only the pass process used in fully electric vehicles, have been improved to overcome these environmental and energy problems over the last ten years. Clearly, these vehicles are better than conventional vehicles in terms of fuel economy, but the aim of developing vehicle technologies is to produce fully electric vehicles [23].

Due to their various benefits, including zero emissions, electric buses are currently being introduced in more and more cities worldwide for public transportation purposes. Special vehicle public transport is generally regarded as relatively sustainable, but, the use of conventional vehicles and buses are not sustainable and damage the environment [24,25]. The use of electric vehicles/buses is a good environmentally friendly and sustainable solution.

This section discusses studies regarding alternative bus technologies and electric buses in the literature. Electric bus technology is indicated in transportation planning in the literature, and literature on multicriteria decision-making in transportation is also given.

2.1. Alternative Bus Technologies and Electric Buses

Populations have increased throughout developed and developing countries, with transportation becoming a significant problem in growing cities. Local administrations are encouraging public transportation systems in order to generate a solution for this problem. In light of this encouragement, services with more modern, economical, and technological systems have been provided.

Nowadays, electric buses are used by an increasing number of cities for public transportation because of their reduced emissions and other social and economic benefits. The total number of electric buses in use around the world increases every year [15]. Academic literature has grown in response to this situation and the development of new technology. In recent years, increased EV-related research has been conducted [26].

Various studies exist regarding the techno-economic and environmental impacts of electric buses. Kühne discussed the energy characteristics of electric battery trolleys in his review study [27]. Ou investigated the energy efficiency of electric buses using an energy consumption model [28]. McKenzie and Durango-Cohen talked about alternative fuels in terms of life-cycle assessments of cost and greenhouse gas emissions [29]. Cooney and Kliucininkas investigated the effect of potential GHG emission reductions from electric buses on the environment [30,31]. Nurhadi concluded that overnight battery-electric vehicles were preferable in terms of cost-effectiveness [32]. Lajunen focused on the cost-benefit analysis of implementing electric buses in transit in his economic study [33]. Ribau optimized operation for alternative powertrains [34]. Li conducted a review of operational and technological demands for battery-electric vehicles [35]. Miles and Potter, Filippo et al., Chao and Xiaohong, and Zivanovic and Nikolic discussed the operational constraints of electric buses [36–39]. Mahmoud et al. presented a review of electric bus technologies in the transit context and aimed at three, in particular, namely, hybrid, fuel cell, and battery [9].

Furthermore, Lin et al., Wang et al., and An studied electric vehicle charging infrastructure planning and design [40–42]. Lajunen and Lipman studied lifecycle cost assessment [33]. Rogge et al. studied battery EV scheduling [43]. Schneider et al. studied electric vehicle (EV) battery charging and purchasing optimization [44]. Brendel et al. and Xu et al. studied EV-based car-sharing system optimization [45,46]. Gao et al. studied battery capacity and recharging [47]. Krause et al. looked at EV usage potential [48]. Wang et al., Erdoğan and Miller-Hooks, Said et al., and Yang, et al. studied the optimization of route choices [49–52]. Zhou et al. studied life-cycle benefits with respect to energy consumption and carbon dioxide emissions [53]. Sun et al. looked at fast-charging station choices and behaviors [54]. Finally, Panchal et al. studied degradation testing and battery modeling [55] and the design and simulation of batteries [56].

2.2. Decision Analysis for the Selection Process

The widespread interest of city managers and planners in public transportation has attracted a great deal of academic interest. Numerous studies were published that ranked or selected alternatives for transportation by using multicriteria decision-making methods, fuzzy and hybrid applications, and analytical methods in recent years. These studies used such methods as analytic network process (ANP), TOPSIS, VIKOR, ELECTRE, fuzzy numbers, and hybrid approaches for the transportation selection process. A complicated selection process must consider various criteria and sub-criteria, otherwise, the model simply cannot lead to correct decision-making. The reviewed literature is briefly summarized in Table 1 in terms of source, year, objective, and study method.

Table 1. Literature review.

Author (Year)	Ref.	Objective	Method
Hamurcu and Eren (2020)	[57]	To improve public transportation technology	TOPSIS-MOORA
Süt et al. (2019)	[58]	Selection of ring vehicles	AHP-TOPSIS
Büyüközkan et al. (2018)	[59]	Selection of sustainable urban transportation alternatives	Fuzzy Choquet integral
Dinç et al. (2018)	[60]	Tramway selection	Fuzzy AHP/AHP
Mukherjee (2017)	[61]	Selection of alternative fuels for sustainable urban transportation	FMCDM
Oztaysi et al. (2017)	[62]	Alternative-fuel technology selection	Interval-valued intuitionistic fuzzy sets
Hamurcu and Eren (2017)	[63]	Monorail technology selection	AHP-TOPSIS
Onat et al. (2016)	[64]	Ranking the life cycle sustainability performance of alternative vehicle technologies	TOPSIS- fuzzy set
Onat et al. (2016)	[65]	Sustainability assessment for optimal distribution of alternative passenger cars	MCDM
Lanjewar et al. (2015)	[66]	Fuel selection	Graph theory - AHP
Yavuz et al. (2015)	[67]	Evaluation of fuel-vehicle	Hesitant fuzzy logic
Petschnig et al. (2014)	[68]	Investigating determinants of alternative fuel vehicle adoption	Structural equation modeling
Aydın and Kahraman (2014)	[69]	Bus selection	Fuzzy AHP-VIKOR
Vahdani et al. (2011)	[70]	Alternative-fuel buses selection	FMCDM
Patil and Heder (2010)	[71]	Investment decision making for alternative fuel public transport buses	MCDM
Hsiao et al. (2005)	[72]	Selecting Low Pollutant Emission Bus Systems	FAHP-TOPSIS
Tzeng et al. (2005)	[73]	Alternative-fuel buses for public transportation	MCDM
Yedla et al. (2003)	[74]	Vehicle selection	AHP

The above literature review clearly indicates that electric vehicles comprise an important research problem from both a theoretical and practical perspective. However, one of the most interesting and challenging problems is electric bus selection due to its specific characteristics under electric vehicle technology. Figure 1 shows some decision alternatives for transportation. The electric vehicle selection problem is a special sub-decision-making process.

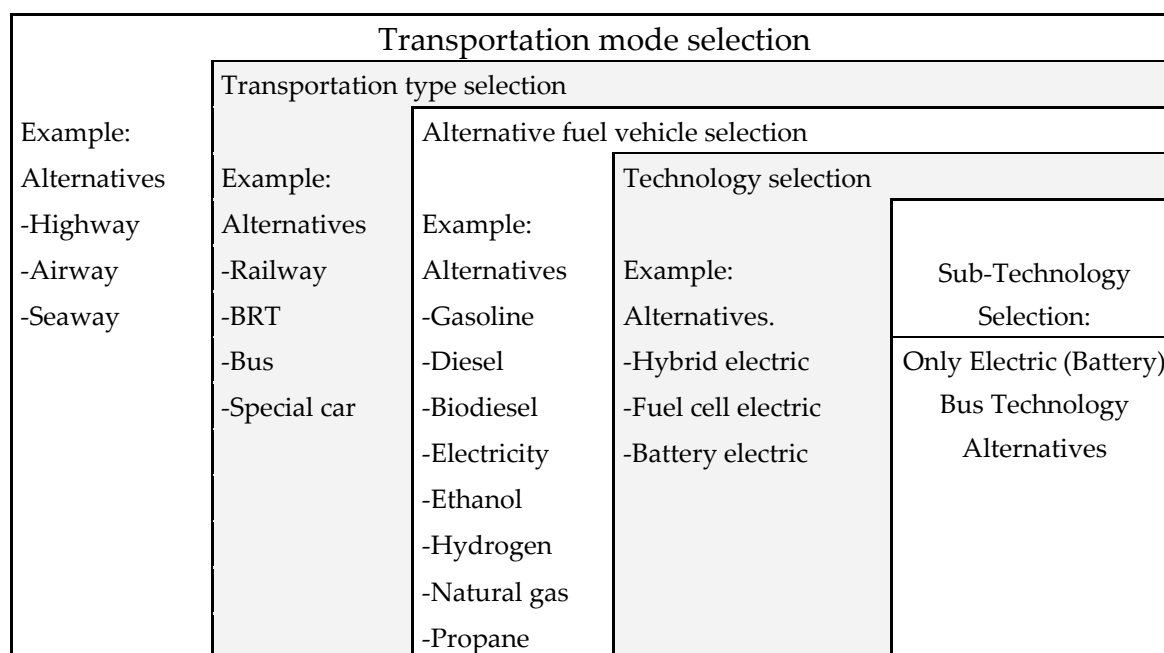

Figure 1. Transportation alternatives.

In light of the discussed literature, we set out three objectives:

- (1) To identify appropriate specific evaluation criteria for electric buses under clean technology,
- (2) To propose an MCDM (AHP–TOPSIS) model to select electric buses for sustainable and environmentally friendly transportation,
- (3) To guide planners regarding the electric vehicle selection process via the example application.

3. Methodology: An Integrated AHP–TOPSIS Method

Many studies exist in the literature regarding the AHP and TOPSIS approaches for transportation planning. Among these, both analytical models and empirical studies have been discussed. This section explains the steps of the AHP–TOPSIS method.

3.1. A Brief Overview of AHP

AHP helps to solve complex decision-making problems and is one of the best-known classical decision-making methods. AHP is a powerful tool that simplifies complicated problems by arranging decision attributes and alternatives in a hierarchical structure with the help of pairwise comparisons [75]. The basics of AHP methodology involve structuring complex decisions as a hierarchy of goals, criteria, and alternatives, conducting a pairwise comparison of all the elements in each level of the decision hierarchy with respect to each criterion in the previous level of the hierarchy, and vertically synthesizing judgments on different levels of the hierarchy [76].

AHP has been applied as a decision-making tool in many contexts due to its simplicity [77]. For instance, it was used in the evaluation and selection of medical tourism sites [78], strategic maintenance technique selection [79], heart disease diagnoses [80], critical criteria influencing the choice of arctic shipping [81], identification of potential aquaculture sites in solar saltscapes [82], ecological vulnerability assessment [83], risk assessment [84], evaluation of high-speed railway (HSR) construction projects [85], selection of suitable sites for wind power in Pakistan [86], and selection of rail system projects [87].

Briefly, the steps of AHP are as follows.

The pairwise comparison for n criteria can be summarized using an $(n \times n)$ evaluation matrix A :

$$A = \begin{bmatrix} a_{11} & a_{12} & \dots & a_{1n} \\ a_{21} & a_{22} & \dots & a_{2n} \\ \vdots & \vdots & \ddots & \vdots \\ a_{n1} & a_{n2} & a_{n3} & a_{nn} \end{bmatrix}, a_{ij} = 1, a_{ji} = \frac{1}{a_{ij}}, a_{ji} \neq 0 \quad (1)$$

In this step, normalize and relative weights are found for each matrix. The relative weights are given by the right eigenvector (w) corresponding to the largest eigenvalue (λ_{max}), according to previous work [60].

$$A_w = \lambda_{max} \times w \quad (2)$$

The quality of the AHP output is strictly related to the consistency of the pairwise comparison judgments. The consistency index (CI) and the consistency ratio (CR) are as follows: (random index (RI))

$$CI = \frac{\lambda_{max} - n}{n - 1} \quad (3)$$

$$CR = \frac{CI}{RI} \quad (4)$$

The number 0.1 is the accepted upper limit for the CR . If the final consistency ratio exceeds this value, the evaluation procedure must be repeated to improve consistency. Consistency is used to evaluate decision-makers and the overall hierarchy [88].

Saaty proposed an important scale for pairwise comparison to help decision-makers, called Saaty's importance scale, where a score of 1 indicates that the factors are equally important, a score of 3 indicates that one is moderately more important, 5 indicates that one is strongly more important, 7 indicates that one is very strongly more important, and 9 indicates that one is extremely more important, with scores of 2, 4, 6, and 8 being intermediate values.

3.2. TOPSIS

The TOPSIS method has a wide range of application areas, such as green supply chain management [89], selection of electric molding machinery [90], assessing organization performances [91], site selection of wind power plants [92], public blockchain evaluation [93], strategy assessment [94], financial performance rankings [95], and solar energy project selection [96].

The TOPSIS method was presented by Jen Chen and Lai Hwang (1992), with reference to Hwang and Yoon (1981) [97,98]. The basic principle in this model with respect to multiple criteria involves the chosen alternative having the shortest distance from the ideal solution and the farthest distance from the negative ideal solution. The ideal solution minimizes cost-type criteria and maximizes beneficial criteria, while the negative ideal solution is the reverse situation. Stated in other words, the optimal alternative is the farthest from the negative ideal solution, therefore, the optimal alternative is geometrically closest to the ideal solution. While the ideal solution is defined using the best value rating alternatives for each individual criterion, the negative ideal solution represents the worst value rating alternative [99].

TOPSIS presents rational and understandable results, with the computational processes including basic mathematics. This method allows us to incorporate important weights of criteria into the comparison procedures. The TOPSIS method consists of the following six steps [100].

Step 1: Establish a decision matrix (D) for the ranking.

$$D = \begin{matrix} A_1 \\ A_2 \\ \vdots \\ A_i \\ \vdots \\ A_j \end{matrix} \begin{bmatrix} f_{11} & f_{12} & \cdots & f_{1j} & \cdots & f_{1n} \\ f_{21} & f_{22} & \cdots & f_{2j} & \cdots & f_{2n} \\ \vdots & \vdots & \cdots & \vdots & \cdots & \vdots \\ f_{i1} & f_{i2} & \cdots & f_{ij} & \cdots & f_{in} \\ \vdots & \vdots & \cdots & \vdots & \cdots & \vdots \\ f_{j1} & f_{j2} & \cdots & f_{ij} & \cdots & f_{jn} \end{bmatrix} \quad (5)$$

where A_j denotes the alternatives $j, j = 1, 2, \dots, J$, F_i represents i th attribute or criterion, $i = 1, 2, \dots, n$ related to i th alternative, and f_{ij} is a crisp value indicating the performance rating of each alternative A_i with respect to each criterion F_j .

Step 2: Calculate the normalized decision matrix $R(=r_{ij})$, where the r_{ij} value is calculated as

$$r_{ij} = \frac{f_{ij}}{\sqrt{\sum_{j=1}^n f_{ij}^2}} = 1, 2, \dots, J; i = 1, 2, \dots, n. \quad (6)$$

Step 3: Calculate the weighted normalized decision matrix (v_{ij}), where v_{ij} is calculated as

$$V_{ij} = w_i * r_{ij}, j = 1, 2, \dots, J; i = 1, 2, \dots, n, \quad (7)$$

where w_i represents the weight of the i th attribute or criterion.

Step 4: Determine the positive ideal (A^*) and negative ideal solutions (A^-).

$$A^* = \{ V_1^*, V_2^*, \dots, V_i^* \} \left\{ \left(\max_j v_{ij} \mid i \in I' \right), \left(\min_j v_{ij} \mid i \in I'' \right) \right\}, \quad (8)$$

$$A^- = \{ V_1^-, V_2^-, \dots, V_i^- \} \left\{ \left(\min_j v_{ij} \mid i \in I' \right), \left(\max_j v_{ij} \mid i \in I'' \right) \right\}, \quad (9)$$

where I' is associated with the benefit criteria and I'' is associated with the cost criteria.

Step 5: Calculate the separation measures. The separation of each alternative from the positive ideal solution and negative ideal solution are as follows:

$$d_{ij}^* = \sqrt{\sum_{i=1}^n (V_{ij} - V_i^*)^2} \quad j = 1, 2, \dots, J \quad (10)$$

$$d_{ij}^- = \sqrt{\sum_{i=1}^n (V_{ij} - V_i^-)^2} \quad j = 1, 2, \dots, J. \quad (11)$$

Step 6: Calculate the relative closeness to the ideal solution and rank the performance order.

$$CC_j^* = \frac{d_j^-}{d_j^- + d_j^+}, j = 1, 2, \dots, J \quad (12)$$

where the CC_j index value lies between 0 and 1. The larger the index value, the better the performance of the alternatives.

3.3. AHP-TOPSIS

AHP is a useful tool to solve complex problems, however, in several cases, it is necessary to combine it with other MCDM methods. TOPSIS is a favorable MCDM method for this purpose [101].

AHP and TOPSIS methods have been used together to solve many complicated decision-making problems in the literature. Jain et al. used AHP and TOPSIS together to evaluate supplier selection [102], Venkatesh et al. used them together to select of supply partners [103]. Bianchini used these methods for 3PL provider selection [104]. Kaya et al. used AHP–TOPSIS in the context of career decision-making regarding uncertainty in the maritime industry [105]. Torkabadi and Mayorga evaluated pull-production control strategies [106]. Jabbarzadeh considered these methods in regard to project management [107]. Karasan prioritized production strategies [108]. Sirisawat and Kiatcharoenpol prioritized solutions for reverse logistics barriers using a combination of these methods [109]. Alakaş et al. used them to select ambulance supplier companies [110]. Özcan et al. maintained strategy optimization using integer programming [111]. Finally, Özcan et al. used AHP–TOPSIS and goal programming to maintain strategy selection in hydroelectric power plants [112].

4. Case Study

The first step for bus electrification feasibility studies is electric bus selection [47], because all planning processes are structured according to electric buses, or electric buses are selected according to transportation plans. Therefore, electric bus selection is an important decision-making process for transportation planning and networks.

In this case study, the hybrid approach was applied to metropolitan cities to select and rank electric buses among six alternatives. The hybrid approach consisted of four stages, including picking up data regarding alternatives, criteria evaluation, finding the weight of criteria using the AHP method, and ranking them using TOPSIS to eventually select electric buses.

The AHP–TOPSIS model was applied to a real problem in urban transportation. The goal of our study was to assess alternative electric bus solutions and help urban transport planners accordingly in terms of technical features.

In this study, an expert group was formed from four university academics and three transport planners from the Ankara municipalities. The expert group determined the criteria to be used in the model and compared the criteria in a pairwise fashion. A flow diagram of the AHP–TOPSIS model and study process for electric bus selection is provided in Figure 2. The decision model for the electric bus selection problem, which was composed of the AHP and TOPSIS methods, consisted of three stages, including preparation for selection, application of AHP, and evaluation of alternatives using TOPSIS to determine the final rank.

The AHP–TOPSIS method was applied to a real urban transportation problem. The aim of our study was to select possible alternative electric bus technologies to make significant developments in the metropolitan area and environment. However, the decision process was difficult when selecting the most suitable buses among alternatives that dominated each other in some features. Technical features of alternative buses were used as a criterion in the model and an academic team was established to evaluate the analytic process. The application is explained step-by-step in this section.

4.1. Criteria Definitions for Electric Bus Selection

Many economical, technical, social, environmental, and technological criteria have been used in the literature to select alternative fuels or fuel vehicles to reduce environmental emissions. Energy availability, energy efficiency, acquisition costs, fuel costs, range, vehicle life, initial costs, maintenance costs, purchase costs, and operating costs come under economic criteria. Vehicle capacity, road capacity, traffic flow, and conformance are considered technical criteria. Passenger comfort stands, energy efficient, fuel availability, air pollution, noise, pollution, emission reductions, and dematerialization are under social criteria. Air pollution and noise pollution come under the umbrella of environmental and performance safety. Finally, sense of comfort, vehicle capacity, and user acceptance are technology criteria.

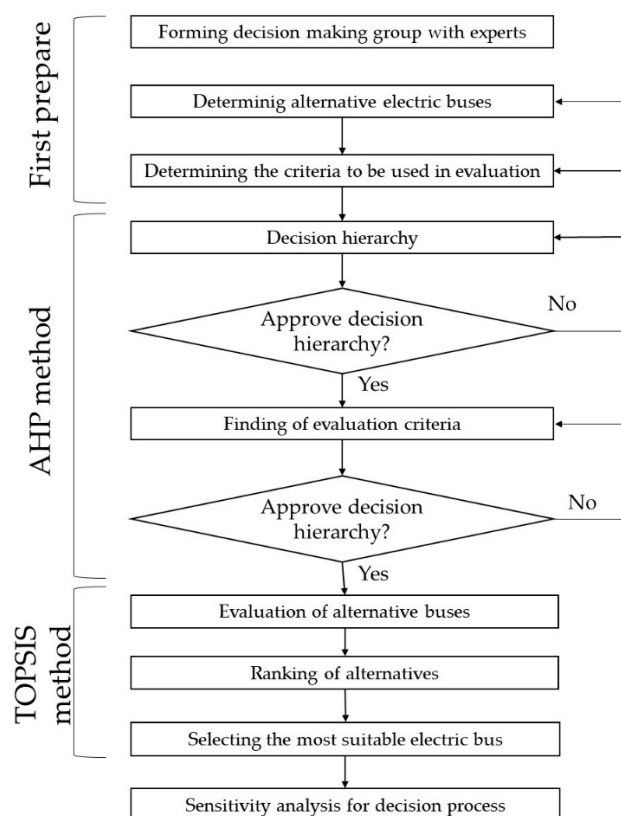

Figure 2. Flow diagram for electric bus selection.

Passenger expectations of public transportation include fast, comfortable, safe, and timely transportation. To this point, we only used technical specifications of electric buses, such as speed, range, capacity, charging time, battery capacity, and maximum power.

Criterion C1—Speed: Fast transportation and mobility are preferable to residents, therefore, the speed of electric buses is an essential factor when it comes to alternatives vehicles.

Criterion C2—Passenger capacity: This criterion is a critical factor for planners and active transportation. City managers would like to serve more residents and decrease the number of private vehicles on roads.

Criterion C3—Range: Electric vehicles have limited range, therefore, this factor is a critical specific feature. Longer range means greater network area involvement.

Criterion C4—Maximum Power: This feature deals with climbing capacity but does depend on the electric motor.

Criterion C5—Battery capacity: The capacity of batteries like fossil fuels ensures greater range and time efficiency.

Criterion C6—Charging time: Short charging times or nocturnal charging is essential for the continuation of bus services.

One of the most challenging tasks for electric bus selection involves the decision process considering the limited driving range and charging requirement constraints. Planners are continuing the popularization of electric buses in urban areas by increasing battery capacity, range, and speed and reducing charging times in combination with technology development.

A hierarchical model was constructed with three levels using various criteria and alternatives (Figure 3). The proposed structure included an ultimate goal, six criteria, and six alternatives. Table 2 shows the pairwise comparison matrix between the criteria.

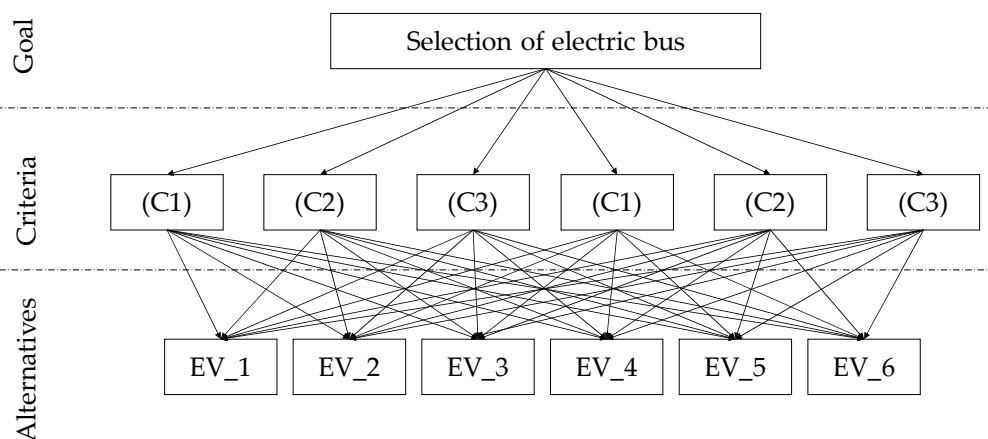

Figure 3. The decision hierarchy regarding electric buses.

Table 2. The pairwise comparison matrix used for the criteria.

Criteria	(C1)	(C2)	(C3)	(C4)	(C5)	(C6)
(C1)	1.0000	0.3333	0.3333	1.0000	0.3333	0.3333
(C2)	3.0000	1.0000	1.0000	1.0000	0.3333	0.3333
(C3)	3.0000	1.0000	1.0000	3.0000	0.3333	0.3333
(C4)	1.0000	1.0000	0.3333	1.0000	0.3333	1.0000
(C5)	3.0000	3.0000	3.0000	3.0000	1.0000	3.0000
(C6)	3.0000	3.0000	3.0000	1.0000	0.3333	1.0000

We calculated the weights according to the AHP method, with weight values presented in Table 3 revealing that the three most important performance criteria for bus selection were battery capacity (C5), 0.3428, charging time (C6), 0.2123, and range (C3), 0.1529. In addition, $\lambda_{max} = 6.5612$, $CI = 0.11224$, and the consistency ratio of the pairwise comparison matrix was calculated as $0.0905 < 0.1$. Therefore, the weights were shown to be consistent and were used in the selection process. There are several reasons to prefer electric vehicles, but low battery range and charging duration, in particular, inhibit electric vehicle (EV) adoption [48]. In our study, charging times and battery capacity were seen to be the two most important criteria.

Table 3. Criteria weights.

Criteria	AHP Weights (w)	λ_{max} , CI, RI	CR
(C1)	0.0710	$\lambda_{max} = 6.5612$	0.0905
(C2)	0.1196		
(C3)	0.1529	CI = 0.11224	
(C4)	0.1014	RI = 1.24	
(C5)	0.3428		
(C6)	0.2123		

4.2. Ranking of Alternatives with TOPSIS

Here, alternatives were ranked using TOPSIS. The proposed AHP–TOPSIS decision model was applied to select a suitable electric bus. After obtaining the local weights of the criteria via AHP, the decision matrix was constructed. Electric busses used at various cities in the world are helped as decision alternatives in this study. For the purpose of the selection of electric bus, the quantitative data used are shown in Table 4. Table 5 shows the attribute values of each electric bus alternative for the TOPSIS method. We used these values for the TOPSIS method as the initial decision matrix. Firstly, in the table, the electric buses are considered as the alternatives and these are placed in the rows. The criteria or attributes are placed in columns.

Table 4. Alternatives to electric bus technology.

Characteristics	Unit	Alternatives					
		EV_1	EV_2	EV_3	EV_4	EV_5	EV_6
Speed	km/h	72	68.4	90	80	75	75
Passenger capacity	—	50	58	50	57	90	136
Range	km	200	200	280	50	280	300
Max. Power	kW	360	360	103	200	250	250
Battery Capacity	kWh	350	394	170	200	230	346
Charging Time	h	2	1.25	7	2	5	7

Table 5. Evaluation matrix for alternative buses.

Alternatives	Criteria					
	K1	K2	K3	K4	K5	K6
EV_1	72	50	200	360	360	2
EV_2	68.4	58	200	360	394	1.25
EV_3	90	50	280	103	170	7
EV_4	80	57	50	200	200	2
EV_5	75	90	280	250	230	5
EV_6	75	136	300	250	346	7

After normalizing the decision matrix, it was multiplied by the weights of the criteria obtained from the AHP method to derive the weighted normalized decision matrix according to Table 5 and expression (6). Table 6 shows the weighted normalized decision matrix.

Table 6. Weighted evaluations for alternative buses.

Alternatives	Criteria					
	C1	C2	C3	C4	C5	C6
The weight of AHP	0.0710	0.1196	0.1529	0.1014	0.3428	0.2123
EV_1	0.027	0.031	0.053	0.055	0.170	0.037
EV_2	0.026	0.035	0.053	0.055	0.186	0.023
EV_3	0.034	0.031	0.075	0.016	0.080	0.129
EV_4	0.030	0.035	0.013	0.031	0.095	0.037
EV_5	0.028	0.055	0.075	0.038	0.109	0.092
EV_6	0.028	0.083	0.080	0.038	0.163	0.129

The positive ideal solution and negative ideal solution were calculated using expression (8) and expression (9). The ideal solution was represented by $EV^+ = \{0.034, 0.083, 0.080, 0.055, 0.186, 0.023\}$ and the negative ideal solution was represented by $EV^- = \{0.026, 0.031, 0.013, 0.016, 0.080, 0.129\}$. Finally, the distance between the ideal and negative ideal solutions was calculated using expressions (10) and (11), and the last expression (12) was used for the final ranking. Based on the CC_i values shown in Table 7, the ranking of the electric buses was EV_2, EV_1, EV_6, EV_5, EV_4, and EV_3. The application results indicated that EV_2 was the best, with a CC_j value of 0.7434 according to the determination criteria.

Table 7. Weighted rankings.

Alternatives	d_i^+	d_i^-	CC_j	Rank
EV_1	0.0630	0.1404	0.6902	2
EV_2	0.0552	0.1601	0.7434	1
EV_3	0.1637	0.0618	0.2741	6
EV_4	0.1264	0.0946	0.4281	5
EV_5	0.1092	0.0839	0.4344	4
EV_6	0.1099	0.1210	0.5241	3

4.3. Sensitivity Analysis of the Solution

This section analyzes the criteria weights that were not considered, i.e., whether the criteria would result in ranking change if the priorities were equal. Similar calculations with AHP-weighted TOPSIS were performed for the other alternatives, with the results of the TOPSIS analyses summarized in Table 8. Results of the analysis and the CC_j values obtained are presented in the same table, alongside comparisons with previous values. Based on the CC_j values, the ranking of the alternatives in order of preference was EV_2, EV_1, EV_6, EV_5, EV_4, and EV_3. The proposed model results indicated that EV_2 was the best alternative, with a CC_j value of 0.6257. The best alternative did not change according to the unweighted ranking result.

Table 8. Comparisons of weighted and unweighted rankings.

Alternatives	Weighted CC_j	Weighted Ranking	Unweighted CC_j	Unweighted Ranking
EV_1	0.6902	2	0.5855	2
EV_2	0.7434	1	0.6257	1
EV_3	0.2741	6	0.3339	6
EV_4	0.4281	5	0.3994	5
EV_5	0.4344	4	0.5198	4
EV_6	0.5241	3	0.5669	3

Since the results of TOPSIS depended on the weight coefficient of the evaluation criteria, this section presents an analysis of the sensitivity of the results to change in criteria weights. The rankings occasionally varied with minimal change in the weight coefficient. We used three different weight coefficients, 0.25, 0.50, and 0.75, in the sensitivity analysis, with each criterion weight changing according to these coefficients, respectively. Eighteen sensitivity analysis scenarios using new criteria weights are given in Table 9.

Table 9. Sensitivity analysis scenarios.

Scenario	Weight Criteria	Rate of Change	New Weight Criteria
S1	C1 = 0.0710	1.25 × C1	0.0888
S2	C2 = 0.1196	1.25 × C2	0.1495
S3	C3 = 0.1529	1.25 × C3	0.1911
S4	C4 = 0.1014	1.25 × C4	0.1268
S5	C5 = 0.3428	1.25 × C5	0.4285
S6	C6 = 0.2123	1.25 × C6	0.2654
S7	C1 = 0.0710	1.50 × C1	0.1065
S8	C2 = 0.1196	1.50 × C2	0.1794
S9	C3 = 0.1529	1.50 × C3	0.2294
S10	C4 = 0.1014	1.50 × C4	0.1521
S11	C5 = 0.3428	1.50 × C5	0.5142
S12	C6 = 0.2123	1.50 × C6	0.3185
S13	C1 = 0.0710	1.75 × C1	0.1243
S14	C2 = 0.1196	1.75 × C2	0.2093
S15	C3 = 0.1529	1.75 × C3	0.2676
S16	C4 = 0.1014	1.75 × C4	0.1775
S17	C5 = 0.3428	1.75 × C5	0.5999
S18	C6 = 0.2123	1.75 × C6	0.3715

Within each phase of the sensitivity analysis, the weight coefficients of the criteria increased by 25%, 50%, and 75%, respectively. In each scenario, only one criterion was favored, for which the weight coefficient increased by the stated values. The changes in the ranking alternatives during the 18 scenarios in the AHP–TOPSIS method are presented in Figure 4.

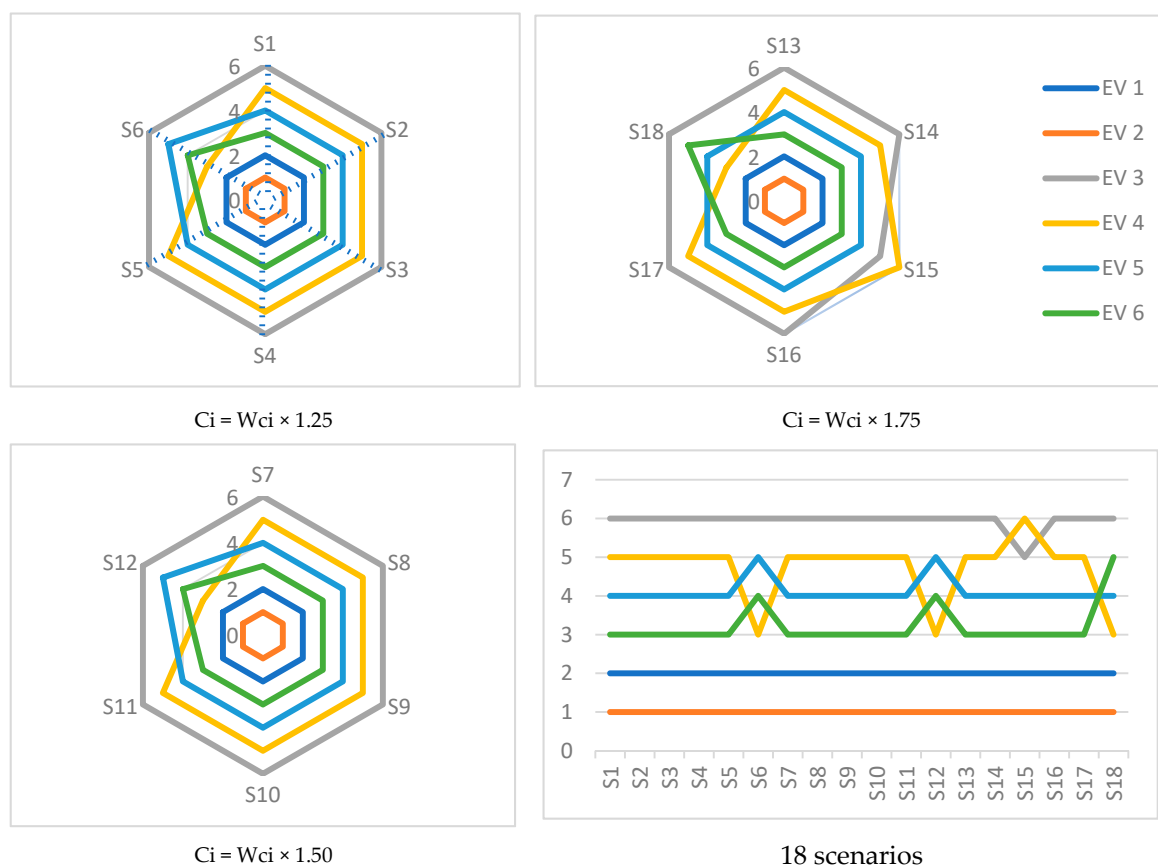

Figure 4. Changes in ranking alternatives through 18 scenarios.

The results showed that, out of the 18 scenarios, assigning different weights to the criteria did not lead to a significant change in the alternative rankings. By analyzing the rankings through 18 scenarios, the EV_1 and EV_2 alternatives kept their rankings throughout all 18 scenarios. The AHP-weighted TOPSIS rankings did not change in any scenario, and the use of AHP did not improve the TOPSIS results. However, distances between the preference rankings in the AHP–TOPSIS hybrid model increased and became more apparent, therefore, AHP affected the TOPSIS results. Thus, the AHP–TOPSIS ranking was confirmed from the 18 scenarios. A small change was observed in four situations, with three of these changes dealing with the shift in the weight of criterion six. Based on this, it was concluded that there was satisfactory rank closeness and that the proposed AHP–TOPSIS ranking was credible.

5. Results

The AHP method was applied in this study to determine criteria weights, the hybrid method was applied to rank the candidates, and the TOPSIS method was used to compare them in an attempt to match increasing demand for sustainable public transportation services in a developing country. Public transportation is more difficult in countries with large populations, with governments producing policies to reduce exhaust gases. To this point, electric buses are the most suitable vehicles than the alternatives. In this paper, electric bus technology for urban mass transportation was investigated. Electric buses have become more widespread and popular in the public transportation sector, with advantages including reduced emissions, quieter engines, less vibration, and increased comfort for riders. A hybrid AHP–TOPSIS method was implemented to select the best alternative electric bus, where a hierarchy composed of criteria and nine alternatives was firstly determined and the weights of the criteria were determined using AHP. Then, TOPSIS was used to evaluate six alternatives. The EV_2 electric bus in the alternatives was determined to be the best alternative according to the determined

six criteria for mass transportation. According to the result of the AHP and sensitive analysis, the most important factors for the selection of electric buses become battery capacity (C5) with a value of 0.3428 and charging time (C6) with a value of 0.2123.

In future studies, other MCDM methods, such as the analytic network process (ANP), *Vise Kriterijumska Optimizacija I Kompromisno Resenje* (VIKOR), PROMETHEE, and hybrid applications could be used to evaluate the results described in this work. Criteria relationships could be considered using ANP, which could also be used in other urban planning processes related to decision-making. Since only technical performance units were used in this work, different criteria could be used to further develop the decision process in future work.

Electric batteries and electric hybrids for could be selected for propulsion, ultracapacitors, batteries, and fuel cells could be used for energy storage, conductive (plug-in) and inductive (wireless) systems could be used for charging technology, and slow or fast charging systems could be considered as charging strategies under the specific criteria.

The AHP–TOPSIS combined model may contribute to satisfying demand for transparency in public institutes by strengthening the underlying rationale behind bus purchasing decisions. This model could also be used with slight modifications in other decision-making problems in public institutes. In addition, mathematical models could be combined with this model for relevant other applications, and aesthetics, maximum gradeability, maximum torque, charging capacity, and vehicle dimensions could be used as criteria for the evaluation process.

In this study, the decision-making process was limited to only electric vehicle technologies. However, it is clear that the transportation sector requires major technological improvement. With further development of technologies and policies, it is possible that hydrogen vehicles or electric autonomous vehicles will become the norm in the coming years. As such, future studies could focus on the selection of hydrogen, autonomous, or electric vehicles for public transportation purposes.

Nomenclature-Acronyms and Symbols

AHP	analytic hierarchy process
TOPSIS	technique for order performance by similarity to ideal solution
EV	electric vehicle
USA	United States of America
MCDM	multi-criteria decision-making
IEA	international energy agency
GHG	greenhouse gas
ANP	analytic network process
VIKOR	<i>vise kriterijumska optimizacija i kompromisno resenje</i>
ELECTRE	elimination et choix traduisant la realite
MOORA	multi-objective optimization on the basis of ratio analysis
PROMETHEE	preference ranking organization method for enrichment of evaluations
FMCDM	fuzzy multi-criteria decision -making
HSR	high-speed railway
CI	consistency index
CR	consistency ratio
RI	random index
λ_{max}	the eigenvalue

Author Contributions: Conceptualization, M.H. and T.E.; methodology, M.H.; validation, M.H. and T.E.; formal analysis, M.H.; investigation, M.H.; resources, M.H.; writing—original draft preparation, M.H.; writing—review and editing, M.H. and T.E.; supervision, T.E.; project administration, M.H. and T.E. All authors have read and agreed to the published version of the manuscript.

Funding: This research received no external funding.

Conflicts of Interest: The authors declare no conflict of interest.

References

1. Dell'olio, L.; Ibeas, A.; Cecin, P. Modelling user perception of bus transit quality. *Transp. Policy* **2010**, *17*, 388–397.
2. Hilmola, O.P. Benchmarking efficiency of public passenger transport in larger cities. *Benchmark. Int. J.* **2011**, *18*, 23–41. [[CrossRef](#)]
3. Yaliniz, P.; Bilgic, S.; Vitosoglu, Y.; Turan, C. Evaluation of urban public transportation efficiency in Kutahya, Turkey. *Proc. Soc. Behav. Sci.* **2011**, *20*, 885–895. [[CrossRef](#)]
4. Guerra, J.B.S.O.A.; Dutra, L.; Schwinden, N.B.C.; Andrade, S.F. Future scenarios and trends in energy generation in Brazil: Supply and demand and mitigation forecasts. *J. Clean. Prod.* **2014**, *103*, 197–210.
5. Banister, D. *Unsustainable Transport: City Transport in the New Century*, 1st ed.; Routledge: Abingdon, UK, 2005.
6. Shen, J.; Sakata, Y.; Hashimoto, Y. The influence of environmental deterioration and network improvement on transport modal choice. *Environ. Sci. Policy* **2009**, *12*, 338–346. [[CrossRef](#)]
7. Deakin, M.; Curwell, S.; Lombardi, P. Sustainable urban development: The framework and directory of assessment methods. *J. Environ. Assess. Policy Manag.* **2002**, *4*, 171–197. [[CrossRef](#)]
8. UITP. *Autonomous Vehicles: Potential Game Changer for Urban Mobility*; International Association of Public Transport, Policy; UITP: Brussels, Belgium, 2017.
9. Mahmoud, M.; Garnett, R.; Ferguson, M.; Kanaroglou, P. Electric buses: A review of alternative powertrains. *Renew. Sustain. Energy Rev.* **2016**, *62*, 673–684. [[CrossRef](#)]
10. Hannan, M.A.; Lipu, M.H.; Hussain, A.; Mohamed, A. A review of lithium-ion battery state of charge estimation and management system in electric vehicle applications: Challenges and recommendations. *Renew. Sustain. Energy Rev.* **2017**, *78*, 834–854. [[CrossRef](#)]
11. Teoh, L.E.; Khoo, H.L.; Goh, S.Y.; Chong, L.M. Scenario-based electric bus operation: A case study of Putrajaya, Malaysia. *Int. J. Transp. Sci. Technol.* **2018**, *7*, 10–25. [[CrossRef](#)]
12. Wang, T.; Yi, S.; Yang, Y. Performance evaluation method for business process of machinery manufacturer based on DEA/AHP hybrid model. *Chin. J. Mech. Eng. Engl. Ed.* **2007**, *20*, 91. [[CrossRef](#)]
13. IEA. *Global EV Outlook 2017*; OECD/IEA: Paris, France, 2017.
14. Perez, J.C.; Carrillo, M.H.; Montoya-Torres, J.R. Multi-criteria approaches for urban passenger transport systems: A literature review. *Ann. Oper. Res.* **2015**, *226*, 69–87. [[CrossRef](#)]
15. IEA. *World Energy Outlook 2016*; International Energy Agency: Paris, France, 2016; p. 28.
16. Tie, S.F.; Tan, C.W. A review of energy sources and energy management system in electric vehicles. *Renew. Sustain. Energy Rev.* **2013**, *20*, 82–102. [[CrossRef](#)]
17. International Energy Agency. *CO2 Emissions from Fuel Combustion: Highlights*; International Energy Agency: Paris, France, 2017.
18. Jacobson, M.Z. Review of solutions to global warming, air pollution, and energy security. *Energy Environ. Sci.* **2009**, *2*, 148–173. [[CrossRef](#)]
19. Enang, W.; Bannister, C. Modelling and control of hybrid electric vehicles (A comprehensive review). *Renew. Sustain. Energy Rev.* **2017**, *74*, 1210–1239. [[CrossRef](#)]
20. Brahma, A.; Guezennec, Y.; Rizzoni, G. Dynamic optimization of mechanical/electrical power flow in parallel hybrid electric vehicles. In Proceedings of the 5th International Symposium in Advanced Vehicle Control, Ann Arbor, MI, USA, 22–24 August 2000.
21. Schouten, N.J.; Salman, M.A.; Kheir, N.A. Energy management strategies for parallel hybrid vehicles using fuzzy logic. *Control Eng. Pract.* **2003**, *11*, 171–177. [[CrossRef](#)]
22. Delprat, S.; Lauber, J.; Guerra, T.M. Control of a parallel hybrid powertrain: Optimal control. *IEEE Trans. Veh. Technol.* **2004**, *53*, 872–881. [[CrossRef](#)]
23. Li, Z.; Khajepour, A.; Song, J. A comprehensive review of the key technologies for pure electric vehicles. *Energy* **2019**, *182*, 824–839. [[CrossRef](#)]
24. Lajunen, A.; Lipman, T. Lifecycle cost assessment and carbon dioxide emissions of diesel, natural gas, hybrid electric, fuel cell hybrid and electric transit buses. *Energy* **2016**, *106*, 329–342. [[CrossRef](#)]
25. Correa, G.; Muñoz, P.; Falaguerra, T.; Rodriguez, C.R. Performance comparison of conventional, hybrid, hydrogen and electric urban buses using well to wheel analysis. *Energy* **2017**, *141*, 537–549. [[CrossRef](#)]
26. Liu, T.; Ceder, A.A. Battery-electric transit vehicle scheduling with optimal number of stationary chargers. *Transp. Res. Part C Emerg. Technol.* **2020**, *114*, 118–139. [[CrossRef](#)]

27. Kühne, R. Electric buses—an energy efficient urban transportation means. *Energy* **2010**, *35*, 4510–4513.
28. Ou, X.; Zhang, X.; Chang, S. Alternative fuel buses currently in use in China: Life-cycle fossil energy use, GHG emissions and policy recommendations. *Energy Policy* **2010**, *38*, 406–418. [[CrossRef](#)]
29. McKenzie, E.C.; Durango-Cohen, P.L. Environmental life-cycle assessment of transit buses with alternative fuel technology. *Transp. Res. Part D Transp. Environ.* **2012**, *17*, 39–47. [[CrossRef](#)]
30. Cooney, G.; Hawkins, T.R.; Marriott, J. Life cycle assessment of diesel and electric public transportation buses. *J. Ind. Ecol.* **2013**, *17*, 689–699. [[CrossRef](#)]
31. Kliucininkas, L.; Matulevicius, J.; Martuzevicius, D. The life cycle assessment of alternative fuel chains for urban buses and trolleybuses. *J. Environ. Manag.* **2012**, *99*, 98–103. [[CrossRef](#)]
32. Nurhadi, L.; Borén, S.; Ny, H. A sensitivity analysis of total cost of ownership for electric public bus transport systems in Swedish medium sized cities. *Transp. Res. Procedia* **2014**, *3*, 818–827. [[CrossRef](#)]
33. Lajunen, A. Energy consumption and cost-benefit analysis of hybrid and electric city buses. *Transp. Res. Part C Emerg. Technol.* **2014**, *38*, 1–15. [[CrossRef](#)]
34. Ribau, J.P.; Silva, C.M.; Sousa, J.M. Efficiency, cost and life cycle CO₂ optimization of fuel cell hybrid and plug-in hybrid urban buses. *Appl. Energy* **2014**, *129*, 320–335. [[CrossRef](#)]
35. Li, J.Q. Battery-electric transit bus developments and operations: A review. *Int. J. Sustain. Transp.* **2016**, *10*, 157–169. [[CrossRef](#)]
36. Miles, J.; Potter, S. Developing a viable electric bus service: The Milton Keynes demonstration project. *Res. Transp. Econ.* **2014**, *48*, 357–363. [[CrossRef](#)]
37. De Filippo, G.; Marano, V.; Sioshansi, R. Simulation of an electric transportation system at The Ohio State University. *Appl. Energy* **2014**, *113*, 1686–1691. [[CrossRef](#)]
38. Chao, Z.; Xiaohong, C. Optimizing battery electric bus transit vehicle scheduling with battery exchanging: Model and case study. *Procedia Soc. Behav. Sci.* **2013**, *96*, 2725–2736. [[CrossRef](#)]
39. Živanović, Z.; Nikolic, Z. The application of electric drive technologies in city buses. In *New Generation of Electric Vehicles*; InTech: London, UK, 2012.
40. Lin, Y.; Zhang, K.; Shen, Z.J.M.; Ye, B.; Miao, L. Multistage large-scale charging station planning for electric buses considering transportation network and power grid. *Transp. Res. Part C Emerg. Technol.* **2019**, *107*, 423–443. [[CrossRef](#)]
41. Wang, H.; Zhao, D.; Meng, Q.; Ong, G.P.; Lee, D.H. A four-step method for electric-vehicle charging facility deployment in a dense city: An empirical study in Singapore. *Transp. Res. Part A Policy Pract.* **2019**, *119*, 224–237. [[CrossRef](#)]
42. An, K. Battery electric bus infrastructure planning under demand uncertainty. *Transp. Res. Part C Emerg. Technol.* **2020**, *111*, 572–587. [[CrossRef](#)]
43. Rogge, M.; van der Hurk, E.; Larsen, A.; Sauer, D.U. Electric bus fleet size and mix problem with optimization of charging infrastructure. *Appl. Energy* **2018**, *211*, 282–295. [[CrossRef](#)]
44. Schneider, F.; Thonemann, U.W.; Klabjan, D. Optimization of battery charging and purchasing at electric vehicle battery swap stations. *Transp. Sci.* **2017**, *52*, 1211–1234. [[CrossRef](#)]
45. Brendel, A.B.; Lichtenberg, S.; Brauer, B.; Nastjuk, I.; Kolbe, L.M. Improving electric vehicle utilization in carsharing: A framework and simulation of an ecarsharing vehicle utilization management system. *Transp. Res. Part D Transp. Environ.* **2018**, *64*, 230–245. [[CrossRef](#)]
46. Xu, M.; Meng, Q.; Liu, Z. Electric vehicle fleet size and trip pricing for one-way carsharing services considering vehicle relocation and personnel assignment. *Transp. Res. Part B Methodol.* **2018**, *111*, 60–82. [[CrossRef](#)]
47. Gao, Z.; Lin, Z.; LaClair, T.J.; Liu, C.; Li, J.M.; Birky, A.K.; Ward, J. Battery capacity and recharging needs for electric buses in city transit service. *Energy* **2017**, *122*, 588–600. [[CrossRef](#)]
48. Krause, J.; Ladwig, S.; Schwalm, M. Statistical assessment of EV usage potential from user’s perspective considering rapid-charging technology. *Transp. Res. Part D Transp. Environ.* **2018**, *64*, 150–157. [[CrossRef](#)]
49. Wang, Y.; Bi, J.; Guan, W.; Zhao, X. Optimising route choices for the travelling and charging of battery electric vehicles by considering multiple objectives. *Transp. Res. Part D Transp. Environ.* **2018**, *64*, 246–261. [[CrossRef](#)]
50. Erdoğan, S.; Miller-Hooks, E. A green vehicle routing problem. *Transp. Res. Part E Logist. Transp. Rev.* **2012**, *109*, 100–114.
51. Said, D.; Cherkaoui, S.; Khoukhi, L. Queuing model for EVs charging at public supply stations. In Proceedings of the 9th International Wireless Communications and Mobile Computing Conference (IWCMC), Cagliari, Italy, 1–5 July 2013; pp. 65–70.

52. Yang, S.N.; Cheng, W.S.; Hsu, Y.C.; Gan, C.H.; Lin, Y.B. Charge scheduling of electric vehicles in highways. *Math. Comput. Model.* **2013**, *57*, 2873–2882. [[CrossRef](#)]
53. Zhou, B.; Wu, Y.; Zhou, B.; Wang, R.; Ke, W.; Zhang, S.; Hao, J. Real-world performance of battery electric buses and their life-cycle benefits with respect to energy consumption and carbon dioxide emissions. *Energy* **2016**, *96*, 603–613. [[CrossRef](#)]
54. Sun, X.-H.; Yamamoto, T.; Morikawa, T. Fast-charging station choice behavior among battery electric vehicle users. *Transp. Res. Part D Transp. Environ.* **2016**, *46*, 26–39. [[CrossRef](#)]
55. Panchal, S.; Rashid, M.; Long, F.; Mathew, M.; Fraser, R.; Fowler, M. *Degradation Testing and Modeling of 200 Ah LiFePO₄ Battery*; SAE Technical Paper; SAE International: Detroit, MI, USA, 2018.
56. Panchal, S.; Dincer, I.; Agelin-Chaab, M.; Fraser, R.; Fowler, M. Design and simulation of a lithium-ion battery at large C-rates and varying boundary conditions through heat flux distributions. *Measurement* **2018**, *116*, 382–390. [[CrossRef](#)]
57. Hamurcu, M.; Eren, T. Applications of the MOORA and TOPSIS Method for Decision of Electric Vehicle in Public Transportation Technology. *Transport* **2020**, in press.
58. Süt, N.İ.; Hamurcu, M.; Eren, T. An Application of Green Transportation in Campus: A Decision Making Process for Selection of Ring Vehicles. *Gazi J. Eng. Sci.* **2019**, *5*, 9–21.
59. Büyüközkan, G.; Feyzioğlu, O.; Göçer, F. Selection of sustainable urban transportation alternatives using an integrated intuitionistic fuzzy Choquet integral approach. *Transp. Res. Part D Transp. Environ.* **2018**, *58*, 186–207.
60. Dinç, S.; Hamurcu, M.; Eren, T. Multicriteria Selection of Alternative Tramway Vehicles for Urban Transportation. *Gazi J. Eng. Sci.* **2018**, *4*, 124–135.
61. Mukherjee, S. Selection of alternative fuels for sustainable urban transportation under Multi-criteria intuitionistic fuzzy environment. *Fuzzy Inf. Eng.* **2017**, *9*, 117–135. [[CrossRef](#)]
62. Oztaysi, B.; Cevik Onar, S.; Kahraman, C.; Yavuz, M. Multi-criteria alternative-fuel technology selection using interval-valued intuitionistic fuzzy sets. *Transp. Res. Part D Transp. Environ.* **2017**, *53*, 128–148. [[CrossRef](#)]
63. Hamurcu, M.; Eren, T. Selection of Monorail Technology by Using Multicriteria Decision Making. *Sigma J. Eng. Nat. Sci.* **2017**, *8*, 303–314.
64. Onat, N.C.; Gumus, S.; Kucukvar, M.; Tatari, O. Application of the TOPSIS and intuitionistic fuzzy set approaches for ranking the life cycle sustainability performance of alternative vehicle technologies. *Sustain. Prod. Consum.* **2016**, *6*, 12–25. [[CrossRef](#)]
65. Onat, N.C.; Kucukvar, M.; Tatari, O.; Zheng, Q.P. Combined application of multi-criteria optimization and life-cycle sustainability assessment for optimal distribution of alternative passenger cars in U.S. *J. Clean. Prod.* **2016**, *112*, 291–307. [[CrossRef](#)]
66. Lanjewar, P.B.; Rao, R.V.; Kale, A.V. Assessment of alternative fuels for transportation using a hybrid graph theory and analytic hierarchy process method. *Fuel* **2015**, *154*, 9–16. [[CrossRef](#)]
67. Yavuz, M.; Oztaysi, B.; Onar, S.C.; Kahraman, C. Multi-criteria evaluation of alternative-fuel vehicles via a hierarchical hesitant fuzzy linguistic model. *Expert Syst. Appl.* **2015**, *42*, 2835–2848. [[CrossRef](#)]
68. Petschnig, M.; Heidenreich, S.; Spieth, P. Innovative alternatives take action—Investigating determinants of alternative fuel vehicle adoption. *Transp. Res. Part A Policy Pract.* **2014**, *61*, 68–83. [[CrossRef](#)]
69. Aydın, S.; Kahraman, C. Vehicle selection for public transportation using an integrated multi criteria decision making approach: A case of Ankara. *J. Intell. Fuzzy Syst.* **2014**, *26*, 2467–2481.
70. Vahdani, B.; Zandieh, M.; Tavakkoli-Moghaddam, R. Two novel FMCDM methods for alternative-fuel buses selection. *Appl. Math. Model.* **2011**, *35*, 1396–1412. [[CrossRef](#)]
71. Patil, A.; Herder, P. Investment decision making for alternative fuel public transport buses: The case of Brisbane transport. *J. Public Transp.* **2010**, *13*, 115–133. [[CrossRef](#)]
72. Hsiao, H.; Chan, Y.-C.; Chiang, C.-H.; Tzeng, G.-H. Fuzzy AHP and TOPSIS for selecting low pollutant emission bus systems. In Proceedings of the 28th IAEE International Conference, Taipei, Taiwan, 3–6 June 2005; pp. 1–19.
73. Tzeng, G.H.; Lin, C.W.; Opricovic, S. Multi-criteria analysis of alternative-fuel buses for public transportation. *Energy Policy* **2005**, *33*, 1373–1383. [[CrossRef](#)]
74. Yedla, S.; Shrestha, R.M. Multi-criteria approach for the selection of alternative options for environmentally sustainable transport system in Delhi. *Transp. Res. Part A Policy Pract.* **2003**, *37*, 717–729. [[CrossRef](#)]

75. Tavana, M.; Hatami-Marbini, A. A group AHP-TOPSIS framework for human spaceflight mission planning at NASA. *Expert Syst. Appl.* **2011**, *38*, 13588–13603. [[CrossRef](#)]
76. Sánchez-Lozano, J.M.; Rodríguez, O.N. Application of Fuzzy Reference Ideal Method (FRIM) to the military advanced training aircraft selection. *Appl. Soft Comput. J.* **2020**, *88*, 106061.
77. Zheng, G.; Zhu, N.; Tian, Z.; Chen, Y.; Sun, B. Application of a trapezoidal fuzzy AHP method for work safety evaluation and early warning rating of hot and humid environments. *Saf. Sci.* **2012**, *50*, 228–239. [[CrossRef](#)]
78. Roy, J.; Chatterjee, K.; Bandyopadhyay, A.; Kar, S. Evaluation and selection of medical tourism sites: A rough analytic hierarchy process based multi-attributive border approximation area comparison approach. *Expert Syst.* **2018**, *35*, e12232. [[CrossRef](#)]
79. Baidya, R.; Dey, P.K.; Ghosh, S.K.; Petridis, K. Strategic maintenance technique selection using combined quality function deployment, the analytic hierarchy process and the benefit of doubt approach. *Int. J. Adv. Manuf. Technol.* **2018**, *94*, 31–44. [[CrossRef](#)]
80. Nazari, S.; Fallah, M.; Kazemipoor, H.; Salehipour, A. A fuzzy inference-fuzzy analytic hierarchy process-based clinical decision support system for diagnosis of heart diseases. *Expert Syst. Appl.* **2018**, *95*, 261–271. [[CrossRef](#)]
81. Tseng, P.H.; Cullinane, K. Key criteria influencing the choice of Arctic shipping: A fuzzy analytic hierarchy process model. *Marit. Policy Manag.* **2018**, *45*, 422–438. [[CrossRef](#)]
82. Teixeira, Z.; Marques, C.; Mota, J.S.; Garcia, A.C. Identification of potential aquaculture sites in solar saltscapes via the Analytic Hierarchy Process. *Ecol. Indic.* **2018**, *93*, 231–242. [[CrossRef](#)]
83. Wu, C.; Liu, G.; Huang, C.; Liu, Q.; Guan, X. Ecological Vulnerability Assessment Based on Fuzzy Analytical Method and Analytic Hierarchy Process in Yellow River Delta. *Int. J. Environ. Res. Public Health* **2018**, *15*, 855. [[CrossRef](#)]
84. Jing, M.; Jie, Y.; Shou-yi, L.; Lu, W. Application of fuzzy analytic hierarchy process in the risk assessment of dangerous small-sized reservoirs. *Int. J. Mach. Learn. Cybern.* **2018**, *9*, 113–123. [[CrossRef](#)]
85. Chang, Y.; Yang, Y.; Dong, S. Comprehensive sustainability evaluation of high-speed railway (HSR) construction projects based on unascertained measure and analytic hierarchy process. *Sustainability* **2018**, *10*, 408. [[CrossRef](#)]
86. Ali, Y.; Butt, M.; Sabir, M.; Mumtaz, U.; Salman, A. Selection of suitable site in Pakistan for wind power plant installation using analytic hierarchy process (AHP). *J. Control Decis.* **2018**, *5*, 117–128. [[CrossRef](#)]
87. Hamurcu, M.; Alakaş, H.M.; Eren, T. Selection of rail system projects with analytic hierarchy process and goal programming. *Sigma J. Eng. Nat. Sci.* **2017**, *8*, 291–302.
88. Wang, J.J.; Yang, D.L. Using a hybrid multi-criteria decision aid method for information systems outsourcing. *Comput. Oper. Res.* **2007**, *34*, 3691–3700. [[CrossRef](#)]
89. Dhull, S.; Narwal, M.S. Prioritizing the Drivers of Green Supply Chain Management in Indian Manufacturing Industries Using Fuzzy TOPSIS Method: Government, Industry, Environment, and Public Perspectives. *Process Integr. Optim. Sustain.* **2018**, *2*, 47–60. [[CrossRef](#)]
90. Trivedi, A.; Jha, S.K.; Choudhary, S.; Shandley, R. Fuzzy TOPSIS Multi-criteria Decision Making for Selection of Electric Molding Machine. In *Innovations in Computer Science and Engineering*; Springer: Singapore, 2019; pp. 325–332.
91. Gupta, H. Assessing organizations performance on the basis of GHRM practices using BWM and Fuzzy TOPSIS. *J. Environ. Manag.* **2018**, *226*, 201–216. [[CrossRef](#)]
92. Daneshvar Rouyendegh, B.; Yildizbasi, A.; Arikan, Ü.Z. Using Intuitionistic Fuzzy TOPSIS (IFT) in Site Selection of Wind Power Plants in TURKEY. *Adv. Fuzzy Syst.* **2018**, *2018*, 6703798.
93. Tang, H.; Shi, Y.; Dong, P. Public blockchain evaluation using entropy and TOPSIS. *Expert Syst. Appl.* **2019**, *117*, 204–210. [[CrossRef](#)]
94. Ture, H.; Dogan, S.; Kocak, D. Assessing Euro 2020 Strategy Using Multi-criteria Decision-Making Methods: VIKOR and TOPSIS. *Soc. Indic. Res.* **2018**, *142*, 645–665. [[CrossRef](#)]
95. Yadav, S.K.; Kapoor, R. Financial performance ranking of automotive companies in India using TOPSIS method. *Int. J. Bus. Excell.* **2018**, *16*, 149–161. [[CrossRef](#)]
96. Çoban, V.; Onar, S.Ç.; Oztaysi, B.; Kahraman, C. Solar energy project selection by using hesitant Pythagorean fuzzy TOPSIS. In *Data Science and Knowledge Engineering for Sensing Decision Support*; World Scientific: Singapore, 2018; pp. 1107–1114.

97. Chen, S.J.; Hwang, C.L. *Fuzzy Multiple Attribute Decision Making: Methods and Applications*; Springer: Berlin, Germany, 1992.
98. Hwang, C.L.; Yoon, K. Methods for multiple attribute decision making. In *Multiple Attribute Decision Making*; Springer: Berlin/Heidelberg, Germany, 1981.
99. Nouredine, M.; Ristic, M. Route planning for hazardous materials transportation: Multicriteria decision making approach. *Decis. Mak. Appl. Manag. Eng.* **2019**, *2*, 66–85. [[CrossRef](#)]
100. Shih, H.S.; Shyir, H.J.; Lee, E.S. An Extension of TOPSIS for Group Decision Making. *Math. Comput. Model.* **2007**, *45*, 801–813. [[CrossRef](#)]
101. Kaliszewski, I.; Podkopaev, D. Simple additive weighting—A metamodel for multiple criteria decision analysis methods. *Expert Syst. Appl.* **2016**, *54*, 155–161. [[CrossRef](#)]
102. Jain, V.; Sangaiah, A.K.; Sakhuja, S.; Thoduka, N.; Aggarwal, R. Supplier selection using fuzzy AHP and TOPSIS: A case study in the Indian automotive industry. *Neural Comput. Appl.* **2018**, *29*, 555–564. [[CrossRef](#)]
103. Venkatesh, V.G.; Zhang, A.; Deakins, E.; Luthra, S.; Mangla, S. A fuzzy AHP-TOPSIS approach to supply partner selection in continuous aid humanitarian supply chains. *Ann. Oper. Res.* **2018**, *283*, 1517–1550. [[CrossRef](#)]
104. Bianchini, A. 3PL provider selection by AHP and TOPSIS methodology. *Benchmark. Int. J.* **2018**, *25*, 235–252. [[CrossRef](#)]
105. Kaya, A.Y.; Asyali, E.; Ozdagoglu, A. Career decision making in the maritime industry: Research of merchant marine officers using Fuzzy AHP and Fuzzy TOPSIS methods. *Sci. J. Marit. Univ. Szczec.* **2018**, *27*, 95–103.
106. Torkabadi, A.; Mayorga, R. Evaluation of pull production control strategies under uncertainty: An integrated fuzzy AHP-TOPSIS approach. *J. Ind. Eng. Manag.* **2018**, *11*, 161–184. [[CrossRef](#)]
107. Jabbarzadeh, A. Application of the AHP and TOPSIS in project management. *J. Proj. Manag.* **2018**, *3*, 125–130. [[CrossRef](#)]
108. Karasan, A.; Erdoğan, M.; İlbarhar, E. Prioritization of production strategies of a manufacturing plant by using an integrated intuitionistic fuzzy AHP & TOPSIS approach. *J. Enterp. Inf. Manag.* **2018**, *31*, 510–528.
109. Sirisawat, P.; Kiatcharoenpol, T. Fuzzy AHP-TOPSIS approaches to prioritizing solutions for reverse logistics barriers. *Comput. Ind. Eng.* **2018**, *117*, 303–318. [[CrossRef](#)]
110. Alakaş, H.M.; Bucak, M.; Kızıltaş, Ş. Selection of Ambulance Supplier Company with AHP-TOPSIS and AHP-VIKOR Methods. *Harran Univ. J. Eng.* **2019**, *4*, 93–101.
111. Özcan, E.C.; Danişan, T.; Eren, T. A mathematical model proposal for maintenance strategies optimization of the most critical electrical equipment groups of hydroelectric power plants. *Pamukkale Univ. J. Eng. Sci.* **2019**, *25*, 498–506.
112. Özcan, E.C.; Ünlüsoy, S.; Eren, T. A combined goal programming-AHP approach supported with TOPSIS for maintenance strategy selection in hydroelectric power plants. *Renew. Sustain. Energy Rev.* **2017**, *78*, 1410–1423.

